

JM-GLOBE-05

GL20-UB-GM-150-F



BRONZE GLOBE VALVE

Union Bonnet Inside Screw
DN15 – DN50 (1/2" - 2")

John Mills Valves was founded in 1828 and since then has been engaged in the manufacture and supply of valves for the Offshore and Marine markets. We offer a wide range of gate, globe, check and ball valves in bronze and aluminium bronze.

On site at Newcastle we have our own pattern shop, foundry, machine shop, assembly and testing facilities, so we can respond quickly and competitively to customers' needs. Our ISO 9001 Quality Assurance system ensures full traceability and control of quality from quotation through to final despatch.

Description

Bronze Globe Valve, Union Bonnet, Inside Screw, Rising Stem, Plug Type Disc, Non Asbestos Packings, BS 5414 & MSS SP 80 Design, End Connections Female NPT.

Options: Alt Trim Al. Bronze - Monel, St Steel, Locking Device, Soft Seated Disc – Needle Type Disc.

PN 32.	Class 150
Tested Body 48 Bars "H"	Tested Body 30 Bars "H"
Seat 36 Bars "H"	Seat 22 Bars "H"

Maximum Working Pressure

(Subject to end connection)

Class 150 - GL20-UB-GM-150-F
PN32 - GL20-UB-GM-PN 32-F

Materials

1	Body	Gunmetal BS 1400 LG2 C / ASTM B62
2	Bonnet	Gunmetal BS 1400 LG2 C / ASTM B62
3	Union Nut	Gunmetal BS 1400 LG2 C / ASTM B62
4	Disc	Gunmetal BS 1400 LG2 C / ASTM B62
5	Disc Stem Nut	Aluminium Bronze
6	Stem	Aluminium Bronze
7	Packing	Non Asbestos
8	Gland	Aluminium Bronze
9	Gland Nut	Aluminium Bronze
10	Handwheel	Cast Iron
11	Handwheel Nut	Steel ASTM A194 2H
12	Seat	Gunmetal BS 1400 LG2 C / ASTM B62

Specifications

Nom Bore	1/2"	3/4"	1"	1 1/2"	2"
	15mm	20mm	25mm	40mm	50mm
"A" Dim (mm)	76	100	110	143	143
"B" Dim (mm)	110	127	146	185	228
WT. Kg Approx	1.00	1.50	1.80	4.10	6.50

Unless otherwise requested by customer or valve specification, all valves manufactured by John Mills Valves will be fully tested to AP1598.

The information on this data sheet is accurate to the best of John Mills Valves knowledge, however we reserve the right to alter the product specification at any time. For any specific updated detail, please contact us.

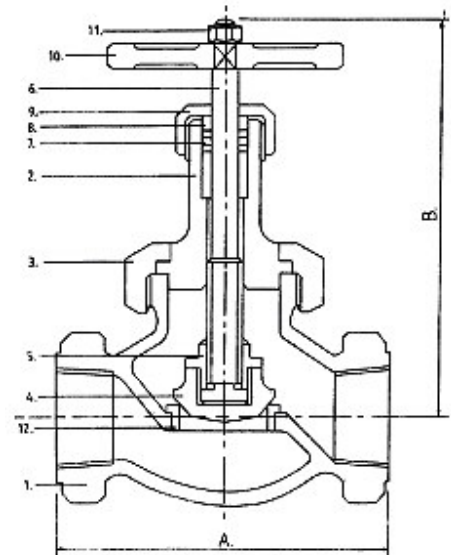

John Mills Valves, 509 Shields Road, Walkergate, Newcastle Upon Tyne, NE6 4PX

Tel: +44 (0) 191 265 6550

Fax: +44 (0) 191 265 1002

E-mail: sales@johnmills-valves.com Website: www.johnmills-valves.com

Revision No: 5
17.04.07