

# JM-GATE-10

GA10-BCIS-RS-GM-150



## BRONZE GATE VALVE

Bolted Cover, Inside Screw, Rising Stem  
DN25 – DN100 (1" - 4")

John Mills Valves was founded in 1828 and since then has been engaged in the manufacture and supply of valves for the Offshore and Marine markets. We offer a wide range of gate, globe, check and ball valves in bronze and aluminium bronze.

On site at Newcastle we have our own pattern shop, foundry, machine shop, assembly and testing facilities, so we can respond quickly and competitively to customers' needs. Our ISO 9001 Quality Assurance system ensures full traceability and control of quality from quotation through to final despatch.

### Description

Gunmetal BS 1400 LG2 Bronze ASTM B 62 Gate, Bolted Cover, Inside Screw, Rising Stem, Solid Wedge, Non Asbestos Joint & Packings, B7/2H Zinc Plated Boltings.

Flanged and Drilled ASA 150 Raised or Flat Faced. Flanges to ANSI B 16.5, Face to Face ANSI B 16.10

Option: Valve to have MONEL Trim, Stem, Wedge, Seat Rings, "Locking" Device,

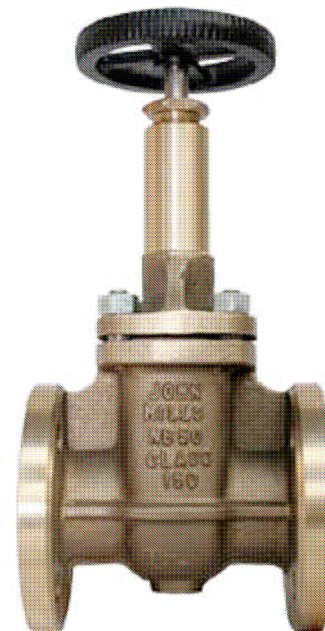

### Maximum Working Pressure

(Subject to end connection)

Class 150

Options: Alternative Trim Available, Aluminium Bronze, Gunmetal

### Materials

1	Body	Gunmetal BS 1400 LG2 ASTM B62
2	Bonnet	Gunmetal BS 1400 LG2 ASTM B62
3	Joint	Non Asbestos Novus 21
4	Wedge	Gunmetal BS 1400 LG2 ASTM B62
5	Stem	Aluminium Bronze ASTM B150 C63200 BS2874 CA104
6	Gland	Aluminium Bronze ASTM B150 C63200 BS2874 CA104
7	Gland Nut	Aluminium Bronze ASTM B150 C63200 BS2874 CA104
8	Packing	Non Asbestos
9	Handwheel	Cast Iron
10	Handwheel Nut	Steel* ASTM A194 2H
11-12	Fasteners	Steel* ASTM B193 B194 B7 / 2H
13	Washers	Option when requested

\* Zinc Plated

### Specifications

Nom Bore	1"	1 ¼"	1 ½"	2"	2 ½"	3"	4"
	25mm	32mm	40mm	50mm	65mm	80mm	100mm
"A" Dim (mm)	127	140	165	178	190	203	229
"B" Dim (mm)	220	330	330	335	415	435	520

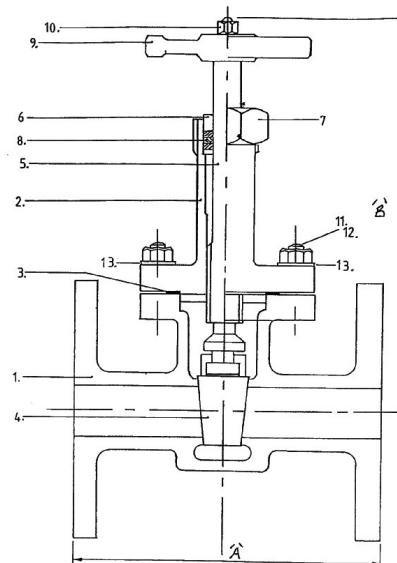

Unless otherwise requested by customer or valve specification, all valves manufactured by John Mills will be fully tested to AP1598.

The information on this data sheet is accurate to the best of John Mill's knowledge, however we reserve the right to alter the product specification at any time. For any specific updated detail, please contact us.

John Mills Valves, 509 Shields Road, Walkergate, Newcastle Upon Tyne, NE6 4PX

Tel: +44 (0) 191 265 6550

Fax: +44 (0) 191 265 1002

E-mail: sales@johnmills-valves.com Website: www.johnmills-valves.com

Revision No: 1

17.04.07