

# JM-GATE-07

GA20-UB-GM-300



## BRONZE GATE VALVE

Union Bonnet – Inside Screw – Rising Stem  
DN15 – DN 50 (1/2” – 2”)

John Mills Valves was founded in 1828 and since then has been engaged in the manufacture and supply of valves for the Offshore and Marine markets. We offer a wide range of gate, globe, check and ball valves in bronze and aluminium bronze.

On site at Newcastle we have our own pattern shop, foundry, machine shop, assembly and testing facilities, so we can respond quickly and competitively to customers' needs. Our ISO 9001 Quality Assurance system ensures full traceability and control of quality from quotation through to final despatch.

### Description

Bronze Gate Valve, Union Bonnet Inside Screw, Rising Stem, Solid Wedge, Non Asbestos Packings, Ends Female NPT, BS 5154 & MSS SP 80 Design.

Options: Monel Wedge & Stem.

### Maximum Working Pressure

(Subject to end connection)

Class 150 or PN 32

### Materials

1	Body	Gunmetal BS 1400 LG2 / ASTM B62
2	Bonnet	Gunmetal BS 1400 LG2 / ASTM B62
3	Union Nut	Gunmetal BS 1400 LG2 / ASTM B62
4	Wedge	Gunmetal BS 1400 LG2 / ASTM B62
5	Stem	Aluminium Bronze
6	Gland	Aluminium Bronze
7	Gland Nut	Aluminium Bronze
8	Packing	Non Asbestos
9	Handwheel	Cast Iron
10	Handwheel Nut	Steel* ASTM A194 2H

\* Zinc Plated

### Specifications

Nom Bore	1/2"	3/4"	1"	1 1/2"	2"
	15 mm	20 mm	25 mm	40 mm	50mm
A Dim (mm)	66	73	76	102	110
B Dim (mm)	152	181	205	280	390

Alternative : - BSP, NPT, Socket Weld Ends  
Class PN32 rated & 150  
General design to BS 5154

Unless otherwise requested by customer or valve specification, all valves manufactured by John Mills Valves will be fully tested to AP1598.

The information on this data sheet is accurate to the best of John Mills Valves knowledge, however we reserve the right to alter the product specification at any time. For any specific updated detail, please contact us.

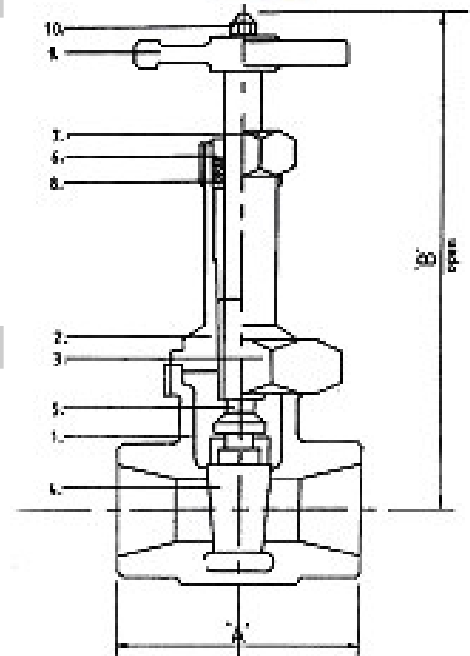

John Mills Valves, 509 Shields Road, Walkergate, Newcastle Upon Tyne, NE6 4PX

Tel: +44 (0) 191 265 6550

Fax: +44 (0) 191 265 1002

E-mail: sales@johnmills-valves.com Website: www.johnmills-valves.com

Revision No: 1

14.04.07